

Structural Health Monitoring: A Dire Need of India

By Gajanan M. Sabnis¹, Yogesh Singh², Abhay Bambole³, Gopal Rai⁴

Abstract

With an advent of all new structures coming up and while India is competing in today's competitive global market, one cannot lose track of the stock that India has in older structures both privately and government owned areas. These have known or unknown deficiencies and will not be identified unless a disaster is experienced. However, it is too late then with a tremendous human loss on hand and the figure-pointing to easy targets. This leads to the present state of the poor affairs and needs a careful consideration to be pro-active to conduct health monitoring and providing proper solution and then it would be up to the owner, may it be private or government to execute it in the national interest.

Structural health monitoring (SHM) in general sense is a process aimed at providing accurate and timely information about the condition and performance of a Structure. It can be either short term (eg. repairs efficacy) or a long term (monitoring parameters continuously or periodically) process . A need for SHM arises with the fact that properties of both concrete and steel depend on large number of factors which are often hard to predict in practice. The representative parameters selected for health monitoring of a structure in general can be of mechanical, physical and chemical in nature.

In India due to negligence and non availability of technology, SHM has not been taken seriously and therefore misses its full potential. If safety standards are emphasized and followed SHM will grow to its full potential and be an integral part of structural maintenance and management. Safety is a serious issue and should be addressed properly in the future.

In this paper, Structural Health Monitoring basics are covered and need for SHM in future in or Indian scenario. Also presented are experiences in some SHM work which has been undertaken and its impact on the structure both in the United States and in India.

Keywords:- Structural Health Monitoring, India, Bridges

¹ CEO , 21 SHM Consultants, Mumbai

² Structural Engineer, 21SHM Consultants, Mumbai

³ Professor, Sardar Patel College of engineering, Mumbai

⁴ CEO, R&M International, Mumbai

1. Introduction

As new materials and technologies are discovered, buildings get taller, bridges get longer spans and the designs of structures become more ambitious, but more complex. In view of these developments, there is an increased requirement to providing both the costs savings with regard to maintenance and a safer environment for by preventing structural failures.

India even being a developing country has picked up the structural developments including the new technologies. India has a rich cultural and historical background which is very well reflected in the varied amount of historical structures. These structures are very well built and have withstood the test of time. But due to their historical importance it becomes very important to assess health condition of these structures, so that appropriate steps can be taken before it is too late.

Apart from old buildings there are high rise buildings made of steel and concrete which have started to make their way in India and as they need extensive modelling, design details and analysis before and during construction it becomes important and good to know about what has been made and its behaviour in future.

Critical buildings (or Lifeline Structures, as they are also called) like hospitals, schools, power plants etc and buildings with large public gatherings like sports arenas, stadiums, commercial buildings, which could cause harm to large amount of people at a time and are something to be taken care on a regular basis, if they suffer any damage due to any calamity, either natural or manmade.

The safety of dams in our country is the principal concern of the State agencies that are involved in the various aspects of their investigation, planning, design, construction, operation and maintenance. While most of the dams have performed well, there have been a few failures. These failures, either partial or complete, highlight the need to review the procedures and the criteria that are being adopted by the various States with the object of establishing the best assurance of dam safety within the limitation of the present state-of-art.

Structural health monitoring (SHM) is a process aimed at providing accurate and in-time Information concerning structural condition and performance on a proactive basis. It consists of (i) permanent continuous, (ii) periodic or (iii) periodically continuous recording of representative parameters, over short or long terms. The information obtained from monitoring is generally used to plan and design maintenance, increase the safety, verify hypotheses, reduce uncertainty and to widen the knowledge concerning the structure being monitored. In spite of its importance, the culture on structural monitoring in India is not yet widespread.

2. Basics of Structural Health Monitoring

The Process of Structural Health monitoring is process similar to the pain and illness experienced by human body and how it is cured.

If the body is considered like a structure^[1]. When a person has some damage or problem with his body, the unhealthy condition is detected by the nervous system and it sends signals to the brain about the issue. Person realizes that he is ill and visits a doctor in order to prevent its further development. Synonymously the sensors act as the nervous system and the acquisition system act as a brain. The Structural expert is like an doctor for the structure and listens to the responses and proposes a solution/repair strategy.

The important aspects are responses in the structure. Responses which can be commonly measured can be in general divided in

- I. **Mechanical:** Strain, Deformation, displacement, cracks opening, stress, load
- II. **Physical:** Temperature, humidity, pore pressure
- III. **Chemical:** Chloride Penetration, sulphate penetration, pH, carbonatation penetration, rebar oxidation, steel oxidation.

The physical diagnostic tool of SHM is the comprehensive integration of various sensing devices and auxiliary systems, including: ^[2]

- i. Sensory system
- ii. Data acquisition system
- iii. Data processing system
- iv. Communication system
- v. Damage detection and modelling system

Monitoring is not supposed to make a diagnosis. To make a diagnosis and propose the cure It is necessary to carry out a detailed inspection and related analyses. Detection of unusual structural behaviours based on monitoring results is performed in accord with pre defined algorithms. The efficiency of monitoring depends on both the performance of the applied monitoring system and the algorithms employed.

3. Aim, Needs and Benefits

The objective of SHM is to monitor the in-situ behaviour of a structure accurately and efficiently, to assess its performance under various service loads, to detect damage or deterioration, and to determine the health or condition of the structure. The SHM system should be able to provide, on demand, reliable information pertaining to the safety and integrity of a structure. The information can then be incorporated into bridge maintenance and management strategies, and improved design guidelines.



Fig 1: Major Civil Structures in which monitoring is required

There are various advantages and positive ramifications of including Structural Health monitoring in civil structures.

1. **Confirm the design parameter:** Detection of damages during construction which can cause any change in properties than expected by design.
2. **Quality Assurance:** By providing continuous and quantitative data, a monitoring system helps you in assessing the quality of your structure during construction, operation, maintenance and repair, therefore eliminating the hidden costs of damages caused by non achieving the required designed standards.
3. **Complex Structures are well managed:** Learning how a structure performs in real conditions will help you to design better structures for the future. When new materials, new technologies and methods are involved in construction monitoring is an effective way to know the real behaviour and to refine Structural behaviour theories.
4. **To Ensure safety of people, nature and property:** Early detection of performance degradation can save lives and property in time by stopping exploitation and access to the structure. This guarantee the safety of the structure and its users. It also gives us a way to assess the possible damages after a natural calamity or any other type of major event which can affect the structural properties and condition.
5. **Monitoring reveals hidden resources:** Many times the structure performance is better than what it is designed for and this gives an extra freedom to play with for further designs and construction.

Economically Structural health monitoring process is also very reasonable and is synonymous to buying an insurance policy for your health. One protects the individual, his/her depending family and finally gives a peace of mind. The same is true for SHM Policy, which gives a much more personal, local and national image for sustainability.

- The cost of installing a system and doing Health monitoring at a given time like construction or repairs is 0.5% to 3% of the total construction or repair costs respectively.

- The cost of doing Structural Health Monitoring for a period of 10 years is 2% to 5% of total structures building cost^[1].

The above points shows that SHM is very economical and the returns are large and worth spending for.

4. Scope of SHM and its need in India

Concrete and Steel are two materials which are mostly used in Construction today, often in the form of Reinforced concrete. These two materials in the form of Reinforced Concrete have become highly popular for construction due to its high compressive strength, resistance to fire, very low maintenance cost as compared to service life, and most importantly it being highly economical. But due to its high requirement of quality control and problems related to reliability with material properties it has some drawbacks. The steel inside the Reinforced Concrete gets corroded. Carbonation is a problem. Ageing phenomenon of concrete is very difficult to predict and this can lead to accidents and losses. Reinforced Concrete structures in critical places like nuclear plants makes them so important that we have to be sure that they are in good condition. This is where Structural health monitoring has a role to play. It gives a way to overcome these drawbacks with minimal damage and loss.

4.1. Steps Involved with SHM.

The following major steps are involved in overall process of structural health monitoring.

- Identify structures needing monitoring
- Acquire information on probable degradation mechanisms and risks from design engineers or owners of structure.
- Establish expected responses to degradations.
- Design SHM system to detect such conditions and select appropriate sensors.
- Install and calibrate system (Fig 2).
- Acquire, Analyse and manage data. This involves alarming the concerned people whenever there is an emergency (Fig 3).

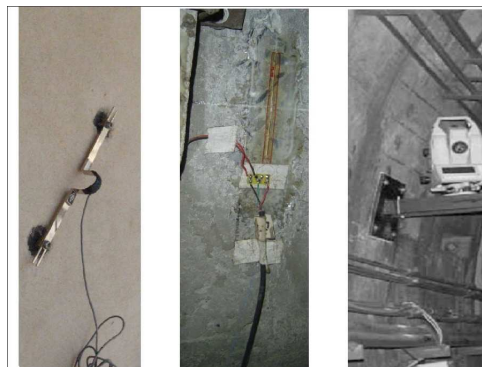

Fig 2: Various sensors installed for assessing data.



Fig 3: Data acquisition from various sensors which are logged for analysis.

4.2. Status of Structural Health Monitoring, World

Major drivers in this area have been the oil industry, operators of large dams and highways agencies, whose installations have received the greatest attention and research effort. Also the need to keep culturally important structures in good health has given SHM attention.

Although worldwide SHM is a relatively new term in civil engineering industry, the use of instruments to assess the health is not new. Bridge field testing using various measuring instruments is very old activity. The objectives of SHM are consistent with the objectives of many of these long standing practices. SHM is in fact an augmentation of current practice.

According to International Society of Structural health Monitoring and Intelligent Infrastructure (ISHMII) lot of bridges and structures have been installed with sensors and are monitored for any damage in European countries^[3]. This is primarily because of the European culture having its root way back in the past. This allows them to retain a stock of old structures, which have to be maintained in good condition to represent their culture. This has driven the SHM of these structures and made them popular. ISHMII provides reference of many bridges being monitored presently all over Europe. Some Asian countries which have seen very high growth in recent times due to the manufacturing and technology revolution, namely China, Singapore, Japan, Taiwan, have many structures under monitoring and are doing well.

In USA the number isn't high but appreciable work has been done. Many universities have been involved with research in Structural health monitoring and have also installed them on bridges and buildings. . There are many reasons. First, unlike Europe or our country, the US structures are fairly young (less than 300 years, compared to several centuries for us). Second, the structures are marked as Historic by the US regulations, which are maintained and cannot be altered. The Historic American Buildings Survey (HABS) and the Historic American Engineering Record (HAER) have considerable information on the subject and have an excellent Website.^[7]

Their collections document achievements in architecture, engineering, and design in the United States and its territories through a comprehensive range of building types and engineering technologies including examples as diverse as the **Pueblo of Acoma, houses, windmills, one-room schools, the Golden Gate Bridge**, and buildings designed by **Frank Lloyd Wright**. Administered since 1933 through cooperative agreements with the National Park Service, the Library of Congress, and the private sector, ongoing programs of the National Park Service have recorded America's built environment in multi-format surveys comprising more than 556,900 measured drawings, large-format photographs, and written histories for more than 38,600 historic structures and sites dating from Pre-Columbian times to the twentieth century.

India has much more to do professionally. A lack of general awareness and reluctance towards trying new technology and methods may have kept us behind on this. There are government records of many historical buildings, which are not easily available to the public for further professional study and research. One can call it in a simplistic manner, Report Card for Infrastructure (as in the US) in a national policy level. In india we can learn from the West for improving our conditions much faster as the information is available, communication is simpler and the world has become much smaller to work.

4.3. Status and need of SHM, India

Residential Buildings and Commercial Structures in india have received very less almost inexistent focus on structural health monitoring primarily due to owners not knowing about its availability and poor knowledge about them. In these cases SHM can only be made possible and implemented in these structures after some efforts have been made to make them aware and educate them or forcing them into it by legally making rules. Some insurance plans can also be worked out for them.

Dams are structures of great national importance. Dams generally serve the primary purpose of retaining water, while other structures such as floodgates or levees (also known as dikes) are used to manage or prevent water flow into specific land regions. Hydropower and pumped-storage hydroelectricity are often used in conjunction with dams to provide generate electricity. A dam can also be used to collect water or for storage of water which can be evenly distributed between locations.

In India dams are majorly owned by state government or the agencies governed by state government. A Report on dam safety procedures has revealed that on the instrumentation side, which is vital for monitoring of dam safety, there appears to be a communication gap between the officer-in-charge of design / construction and officers who take over maintenance^[4]. There are many instances where the officers in charge of maintenance are not aware of the instrumentation proposal that has gone into the dam and there exist many missing links. The initial readings of the instrument are rarely available for an instrument embedded in the dam, the absence of which has made subsequent analysis difficult.

Bridges are important lifeline structures, it is important for them to have elaborate inspection and maintenance programmes. Static and Dynamic Load testing's are carried out in today's bridges to satisfy the IS codes and safety measures. These tests are carried only during major events in the bridge lifespan especially the construction time and major repairs & retrofitting. Apart from this Permanent & Continuous monitoring are required for majority of bridges to prevent any human loss. These can be also useful to assess the distress during or following any major event like earthquake, landslides, storms etc.

Modal Analysis has come up as a very effective way of finding Damages and overall health of bridges. Such Global methods are very important but can only detect only global changes such as foundation settlement, bearing failure or major defects, such as loss of main cable tension or rupture of deck element . But again does not need a high density of sensors and can be done minimum of optimally located sensors.

Some work of installing advance Structural Health Monitoring has been done in india on very few bridges. One of the bridge is **Naini Bridge over Yamuna River** at Allahabad. This was probably the first installation of fully standalone new generation GPS combined with advance post processing software to continuously monitor the bridge for various changes in climate and operations with high accuracy for example 3D absolute deflections can be measured up to mm accuracy^[5]. This work was carried out by COWI/ Devcon Infrastructure Pvt. Ltd. But this kind of work has to be carried over all important bridges for there better understanding and safety.

The ASCE Infrastructure report card^[6] was devised under the leadership of American Society of Civil Engineers (ASCE) in 1997, in which the senior author was personally involved. It reveals some important facts about Infrastructure and also gives a lesson in making us, as professionals, more responsible for the national stock. We as Profession must guide and direct such activity in India to make public aware of the future of our infrastructures.

A structurally deficient bridge is closed or restricted to light vehicles because of its deteriorated structural components. While not necessarily unsafe, these bridges must have limits for speed and weight. A functionally obsolete bridge has older design features and, while it is not unsafe for all vehicles, it cannot safely accommodate current traffic volumes, and vehicle sizes and weights. These restrictions not only contribute to traffic congestion, they pose such major inconveniences as school busses or emergency vehicles taking lengthy detours.

Between 2000 and 2003, the percentage of the nation's 590,750 bridges rated structurally deficient or functionally obsolete decreased slightly from 28.5% to 27.1%. However, it will cost \$9.4 billion a year for 20 years to eliminate all bridge deficiencies. Long-term underinvestment is compounded by the lack of a Federal transportation program.

Since 1998, the number of unsafe dams has risen by 33% to more than 3,500. While federally owned dams are in good condition, and there have been modest gains in repair, the number of dams identified as unsafe is increasing at a faster rate than those being repaired. \$10.1 billion is needed over the next 12 years to address all critical non-federal dams--dams which pose a direct risk to human life should they fail.

5. Case Study

5.1. Mahatma Gandhi Setu



Fig 4: The Mahatma Gandhi Setu over Ganges river in patna.

The Mahatma Gandhi Bridge was constructed about 25 years ago over the Ganges River in order to connect patna to the other side of river. The bridge has 46 spans each with length 120m. Each span has two cantilever beams on both sides which are free to move at the ends. It has two lanes one upstream and the other downstream each with a width of around 6m. Both the lanes are also free from each other and are not connected anywhere. It was constructed by using 3 meter pre-casted parts being joined at both ends to complete the span. Due to heavy traffic movement and being the only bridge to cross ganges river the bridge is used heavily now. Hence it has started vibrating with a higher amplitude than it was designed to. Also in many spans the cantilever beams were found to have sagged at ends.

5.1.2. The Rehabilitation Process:

External Pre-stressing of the bridge using 9 steel cables in a bunch (Fig 5). It was decided to pre-stress from 6 places starting from the end towards the center portion as shown in fig 5. .

The Rehabilitation work was carried out by the **Freyssinet Prestressed Concrete Company (FPCC) Ltd.**

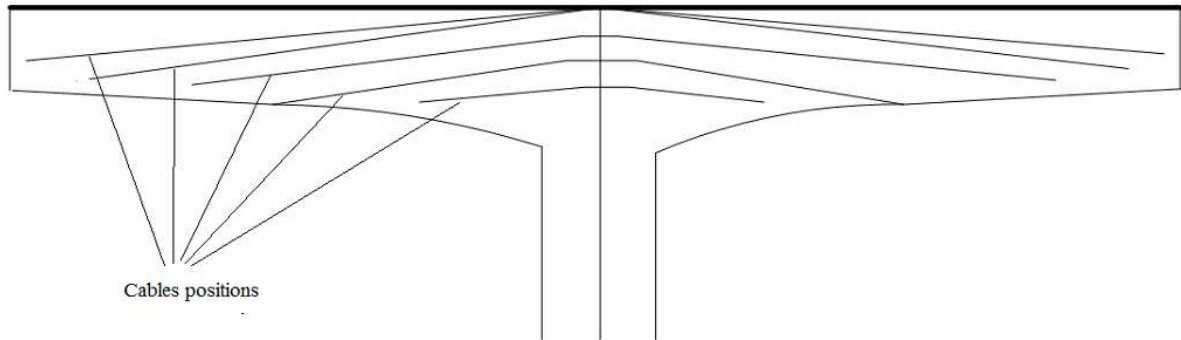

Fig 5: The Rehabilitation using external Pre-Stressing using steel tendons.

5.1.3. Instrumentation Process

For measuring the effectiveness of external Pre-stressing following parameter measurements were carried out in the bridge spans before and after rehabilitation work.

The Instrumentation work was done by **Sardar Patel College of Engineering, Mumbai** under guidance of Prof. Abhay Bambole.

Strain measurements:-

Strain Gauges were installed at 24 places as follows. As each cantilever span is pre-stressed the strain in the span is relived and to correctly measure all the strain change in the top, bottom, and the two side slabs strain gauges were installed at these parts. There were total six cross-sections were identified. At each cross-section the gauge placement plan is shown in Fig 6.

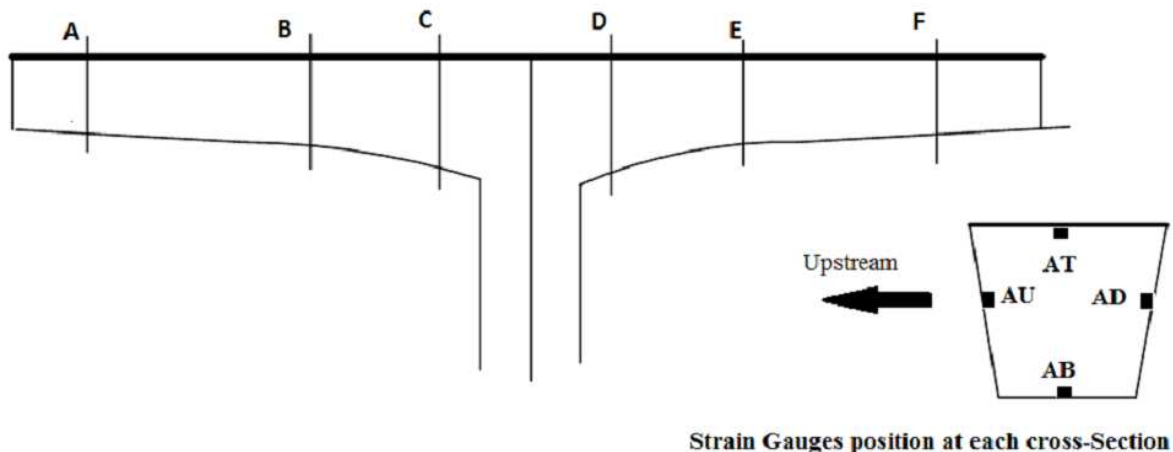

Fig 6: The Scheme for placement of Strain Gauges inside the span and their notation.

The gauges were named according to there positions. Each cross-section was named from A to F starting from patna side. At each cross-section the one at the top is suffixed by a T, the one at the bottom by B, the one in the upstream direction side wall by U and the one in the

downstream direction side-wall by D. Hence AT will be the gauge at top and in A cross-section, BB will be gauge at bottom in B cross-section and likewise.



Fig 7: The Strain Gauge (Type PL-90 of TMU make) Dummy sensor, the Data Acquisition System using switcher units and a read out instrument.

All Strains were measured throughout the day at different intervals so that the strains before the prestressing are known at all times and can be compared with strains when all tendons are stressed as it takes 4-5 hours. The strain gauges and the Data Acquisition system is shown in Fig 7.

Deflection measurements:-

When the span is externally prestressed by cables it causes the tip of the cantilever arms to move up with respect to the middle of the centre of span. The cables pull the arms upward due to the stressing done. To confirm this it is necessary to note down the initial deflection and the final deflection after prestressing by cables. This is done by putting water tubes at both ends of the span. Three pipes are used two at the ends along the width of arm and one at the middle. The initial and the final readings are taken on a scale with a least count of 1mm on both sides of all 3 pipes. The difference between one side reading and the other side reading gives the deflection and comparing the deflections before and after stressing we can get the effective change caused by Pre-Stressing.

Temperature measurements:-

Temperature variations through out the day are quite significant. As they cause the stress to increase or relive and also the deflection in the cantilever arms to vary. It is important to consider the effect of temperature. For this purpose PT type sensors are installed at the surface inside and outside surface the bridge. The ambient temperature thermometer is also installed outside and inside the bridge span. The readings of before stressing and after stressing are compared according to the time and temperature at which they are taken. This further refines the readings to find efficacy of Pre-Stressing.

Conclusions and results by Instrumentation: Summary of strain and tip recovery measurements. To obtain net effect due to stressing only, Strains induced in structure due to thermal expansion of box girder has to be deducted from the strain values obtained to obtain actual effect of stressing on the structure. Results are tabulated in Table 1.

Span no.	Average Micro Strains of Top			Average micro strains of Bottom		
	AT/ FT	BT/ ET	CT/ DT	AB/ FB	BB/EB	CB/DB
P-28	-25.00	-17.00	-52.00	-14.5	+18.00	+19.50
P-29	-19.00	-38.50	-60.50	-31.00	-21.00	-33.00
P-26	-28.90	-35.15	-48.00	-	-	-4.00
P-35	-20.20	-18.70	-18.30	-9.00	-13.40	-14.70
P-34	-14.50	-40.50	-39.50	-23.50	-41.50	-12.50
P-23	-17.65	-43.05	-60.45	-21.20	-24.70	-7.45
P-16	-98.75	-63.00	-69.80	-5.20	-28.00	-6.50
P-2	-29.30	-13.7	-24.30	-31.50	-41.70	-10.80

Table 1: Summary of strain measurements for all the spans.

Span no.	Location	Uplift recorded at patna end due to stressing only (mm)	Uplift recorded at hajipur end due to stressing only (mm)
P-28	Upstream Carriageway	21.7	26.7
P-29	Upstream Carriageway	12.0	19.7
P-26	Upstream Carriageway	15.4	24.6
P-35	Upstream Carriageway	8.0	12.0
P-34	Upstream Carriageway	7.7	8.7
P-23	Upstream Carriageway	10.3	11.0
P-16	Upstream Carriageway	26.3	34.3
P-2	Upstream Carriageway	5.1	5.8

Table 2: Results for tip recovery of different spans after Rehabilitation process.

the theoretical estimate of maximum compressive strains for these spans is in order of $100 \mu\epsilon$ at locations of gauge mounted on top slab of box girder near pier. At the locations 25.5 m from the cantilever end is between $70 \mu\epsilon$ to $80 \mu\epsilon$. Similarly theoretical estimate of maximum tip deflections for all the 9 spans under consideration is between 20 to 23mm.

Actual strains and deflections (Table 1 and 2) values have been found lower than the estimates. Maximum value of strain change due to pre-stressing obtained is $70 \mu\epsilon$ and maximum tip deflection recovery values have been recorded as 24 and 34 mm for span P-16. The strain and tip recovery was reasonable for P-28, P-29 and P-26. Whereas, for remaining spans the measured values were appreciably lower than the theoretical estimates.

5.2. Monitoring of Two Girders for deflection, Bending & shear of hotel building in its construction phase at Kanjurmarg, Mumbai

5.2.1. Introduction

A newly constructed Hotel building at Kanjurmarg was to be monitored during its construction phase and afterwards for a span of 10 years. It is presently under construction.

The whole structure is designed to be supported by 4 large semicircular columns. Every two columns are connected by two girders.

The columns were with semicircular in cross-section with diameter 11m. The height of these columns were around 50m. Each girder were to be monitored while construction in each phase.



Fig 8: The Columns and the girder beam(Top view) which is being monitored.

This is one of the complex structure being designed in India and hence it was decided to monitor its behaviour during construction and after construction for strains and deflections mainly in the girders which are supposed to support the whole structure.

1. Two types of strain gauges were installed i) Strain gauges embedded inside the girders and ii) strain gauges over the surface of girders.

2. For measuring deflection with
 - i) 2 LVDT's at middle of the girder and $L/3$ distance from one end, L being the length of the girder.
 - ii) Water tube between column and centre of girder beam to measure deflections.

The monitoring of this building was planned to be done after completion of different phases in construction. The different phases which were identified were.

1. Measuring the deflection and strains developed in the girder after 100% of girder concrete is casted and the temporary supports are removed. If the results were satisfactory the supports were refitted and further construction is done.
2. After girder beams are done the floors are to be constructed over the slab constructed on these beams. The deflection and strains developed were to be measured after completing 7th, 14th & 22nd floor slab.

5.2.2. Methodology for Instrumentation

To measure deflection bending and shear in the girders the different types of sensors and techniques were used which are presented below.

a. Embedded strain gauges

Special strain gauges were put inside the girder beam area before casting which got embedded in the concrete after casting. For this TML make model PMFL- 60T- 3LT was used. A special Casing was designed for making sure that while pouring the concrete the gauge is safe and does not get damaged and at the same time it should get fully in contact with the concrete for sensing the strains developed.

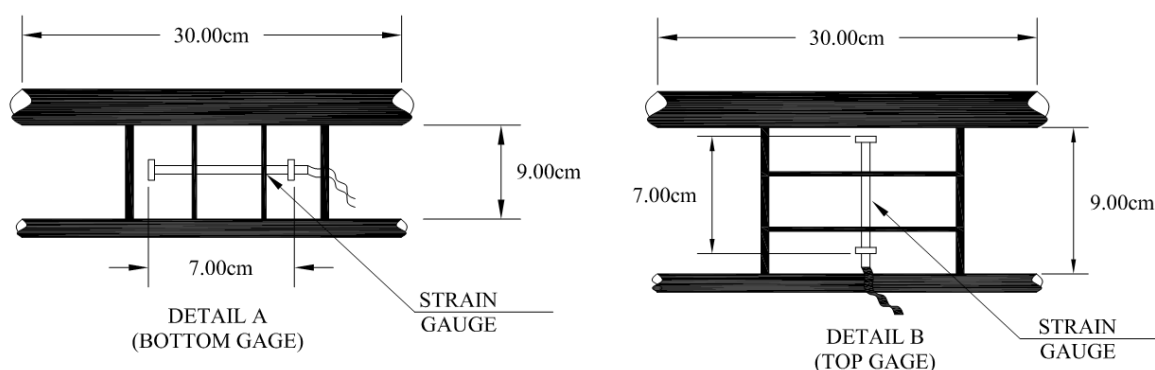

Fig 9: Details of embedded strain gauges with the casing for A) Tension and Compression measurements B) Shear measurements



Fig 10: the Strain Gauges with the protection to keep it safe while casting

In each Girder beam 13 embedded type strain gauges which were embedded inside the concrete beam. The placement is described below

1. 3 gauges inside bottom of these girder beams at the middle of beam length. This is for tension developed at the bottom of these girder beams.
2. 1 gauge at the top middle of beam length. This is for measuring compressive strains developed in different phases during construction.
3. 2 gauges at each end of the girder beam at the top. This is to measure the strains at the joints between column beam.
4. 3-3 gauges at both the ends at an angle of 45 degrees for measuring shear strains in the girder beam.

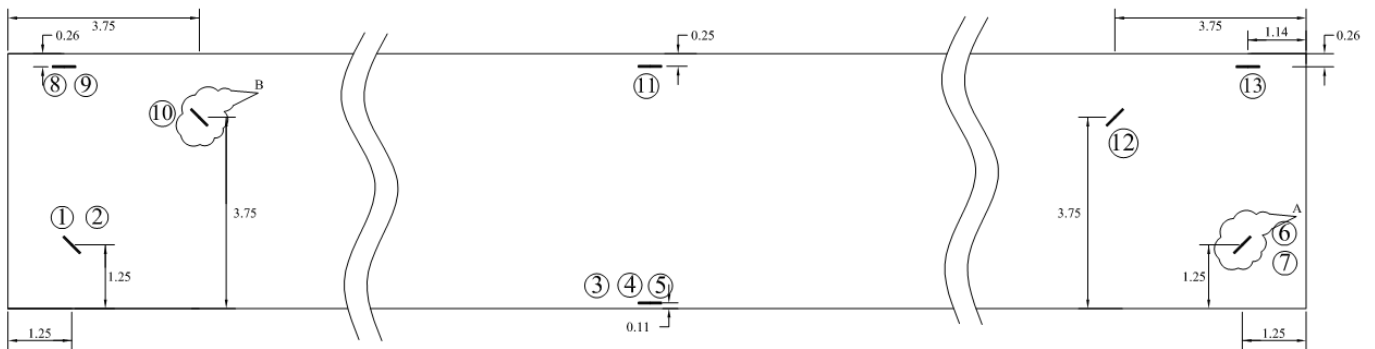

Fig 11: The Placement plan of embedded strain gauges and nomenclature of these embedded Strain Gauges.

1	WSS1	WEST SHEAR SOUTH 1
2	ESS1	EAST SHEAR SOUTH 1
3	MBW1	MIDDLE BOTTOM WEST 1
4	MBC1	MIDDLE BOTTOM CENTRE 1
5	MBE1	MIDDLE BOTTOM EAST 1
6	WSN1	WEST SHEAR NORTH 1
7	ESN1	EAST SHEAR NORTH 1
8	TTSE1	TOP TENSION SOUTH EAST 1
9	TTSW1	TOP TENSION SOUTH WEST 1
10	TSS1	TOP SOUTH SHEAR 1
11	TCC1	TOP CENTRAL COMPRESSION 1
12	TSN1	TOP SHEAR NORTH 1
13	TTN1	TOP RENSIION NORTH 1

b. Surface strain gauges

Surface Strain Gauges were also installed to measure same parameters as the embedded type strain gauges. These strain gauges were installed to cross check the measured strains by embedded gauges. These were also helpful in measuring strains incase the embedded strain gauge has undergone damage and the readings are unacceptable.

The surface strain gauges for shear were installed at side surface just over the embedded strain gauges numbered 1, 10, 6, 12 as in Figure 2.

Surface strain gauges for tension were installed at the bottom surface at middle position just over embedded strain gauge 4 of girder beam.

c. Linear Potentiometers for deflection measurements

When the temporary supports are released for the beam. Stresses are developed in the beam it deflects due to its self weight. Deflection Measurements were to be done after each stage of construction is completed. Two linear potentiometers were installed for each girder beam. One at the middle of beam and other at $L/3$ distance from one end, L being the length of the girder beam.

d. Water level measurement for deflection measurements.

Sometimes the readings by linear potentiometer is not reliable as it requires a stable support with respect to the ground frame which is not possible at higher floors. Due to this limitations water level in a tube which directly uses gravity can be used.

one end of tube is kept in the middle of girder and the other end is fixed to the main column which is fixed. When the girder deflects in middle it changes the water level in the tube by the amount beam has deflected and hence gives us the proper deflection. This is one of the oldest and reliable method of finding difference in level between two points

5.2.3. Results

The Girder beam was casted and the jacks which was holding it was released on 28/8/10. Readings were taken for some embedded strain gauges and some surface gauges before and after the release of jacks. The summary of results obtained by strain measurements for both the girders are presented in Table 3.

Serial no.	Gauge no.	Type	Bridge	Readings Before releasing Jack	Readings after releasing Jack	Difference
1	SES -2	Embedded	Quarter	47	-247	-294
2	SWS-2	Embedded	Quarter	-458	-711	-253
3	SEN-2	Embedded	Quarter	-168	-463	-295
4	SWN-2	Embedded	Quarter	-862	-1222	-360
5	SWS-1	Embedded	Quarter	807	528	-279
6	SES-1	Embedded	Quarter	1829	1598	-231
7	SEN-1	Embedded	Quarter	1568	1315	-253
8	SWN-1	Embedded	Quarter	214	-845	-1059
9	MBW-1	Embedded	Quarter	1155	969	-186
10	MBC-1	Embedded	Quarter	-339	-564	-225
11	MBE-1	Embedded	Quarter	994	730	-264
12	MBW-2	Embedded	Quarter	873	645	-228
13	MBC-2	Embedded	Quarter	364	143	-221
14	MBE-2	Embedded	Quarter	755	578	-177
15	F-1	Surface	Half	-106	-109	-3
16	F-2	Surface	Half	-414	-326	88
17	SS-1	Surface	Half	-921	-903	18
18	SN-1	Surface	Half	-208	-197	11
19	SS-2	Surface	Half	-268	-222	46
20	SS-2	Surface	Half	-793	-765	28

Table 3: Strain gauge measurement for girder 1 and 2 before and after releasing the jacks.

The linear potentiometers were kept on the Scaffolding so it wasn't stable while releasing the jack as the jacks were an extension of the scaffoldings. They couldn't be used for deflection measurements.

The Water level measurements are shown in table for girder 1 and table for girder 2.

Time (hrs)	Water Level Readings before release of jacks			Deflection (cm)
	On North Corner	At Center	Difference	
12:50	15.7	17.9	2.2	0
19:15	16.7	18.5	1.8	-0.4
	Water level reading after release of jacks			
10:00	21.8	23.1	1.3	-0.9
14:50	25.4	26.2	0.8	-1.4
19:20	25.1	25.6	0.5	-1.7

Table 4: water level readings noted for girder 1

Time (hrs)	Water Level Readings before release of jacks			Deflection (cm)
	On North Corner	At Center	Difference	
12:50	21.1	20.0	-1.1	0
19:15	20.8	19.5	-1.3	-0.2
	Water level reading after release of jacks			
10:00	24.7	23	-1.7	-0.6
14:50	26.1	24.2	-1.9	-0.8
19:20	25.2	23.1	-2.1	-1.0

Table 5: Water level readings noted for girder 2

The results shows development of stresses and also the deflections.

The project is still going on and the measurements at remaining phases are still to be carried out. The structure is under monitoring and all the parameters will be again recorded with completion of 7th, 14th and 22nd floor slabs. After this the deflections and strains will be

monitored for a long time so that any change in behaviour ahead in time can be found well in advance.

6. Conclusion and Future:

In the paper many aspects of Structural Health Monitoring were considered.

1. The need of SHM gives us some strong reasons for it to become an integral part of a structure.
2. India as a developing country needs to be more aware and cautious about its Infrastructure. A major event can cause irreversible losses and hence should be well informed in time.
3. There are many important structures where instrumentation is already being used in India like the dams, whose various parameters have to be looked upon, but these are not being done effectively and can be better with new technologies.
4. Lifeline structures like hospitals and important bridges and tunnels should be mandated with monitoring as their failure cause more losses than any other.
5. Structural health monitoring economically is also light and is only 0.5% to 3% one time cost of total structures cost and 2% to 5% for monitoring structure over 10 years.
6. It is done with some structures in India but have to be focused more on.

Structural Health Monitoring is a relatively new concept worldwide and very recent for India. It has proved to be effective and fruitful in many countries, now being practiced often, and has a great potential and usefulness for India for gaining confidence over the structures we are making so that development happens faster and with accurate results.

Acknowledgement: The real cases presented in paper were carried out by Sardar Patel College of Engineering, Mumbai. Sincere thanks to the SPCE and the team which carried out the work.

7. References:-

1. Branko Glisic and Daniele Inaudi, "Fibre optic methods for structural health monitoring", *John Wiley & Sons*, Chichester, **2007**.
2. Guidelines for Structural Health Monitoring, *ISIS Canada*.
3. International Society of Structural Health Monitoring and Intelligent Infrastructure, www.ishmii.org
4. "Report on Dam Safety Procedures", *Government Of India, Ministry of Water Resources*.
5. Jacob Egede Anderson, "Structural Health Monitoring Systems", *Cowi A/S and Futurtec OY*, **2006**.
6. "Report card for America's Infrastructure", *American Society of Structural Engineers*, **2005**.
7. http://memory.loc.gov/ammem/collections/habs_haer/